

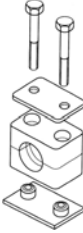





## STANDARD SERIES - Pages 1-3

 <p>Support with weld plate mount, cover plate and hex bolts</p>	 <p>Support with rail nut mount, cover plate and hex bolts</p>	 <p>Support with extended weld plate mount, cover plate and hex bolts</p>	 <p>Stacking support with stack bolts and lock plates</p>
---	---	---	--

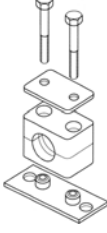
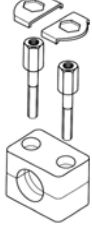
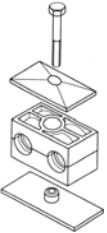
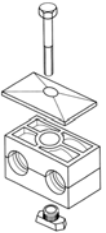
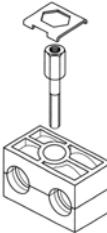
## TWIN SERIES - Pages 4-6

 <p>Support with weld plate mount, cover plate and hex bolts</p>	 <p>Support with rail nut mount, cover plate and hex bolts</p>	 <p>Stacking support with stack bolt and lock washer</p>	
---	---	--	--

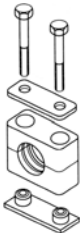
## HEAVY DUTY SERIES - Pages 7-9

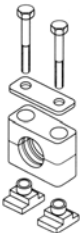
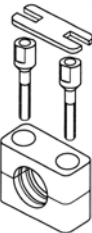
 <p>Support with heavy weld plate mount, cover plate and hex bolts</p>	 <p>Support with double heavy weld plate mount, cover plate and hex bolts</p>	 <p>Support with heavy rail nut, cover plate and hex bolts</p>	 <p>Stacking support with stack bolts and lock plate</p>
---	--	--	---

## TUBE AND PIPE SUPPORTS COMPONENTS

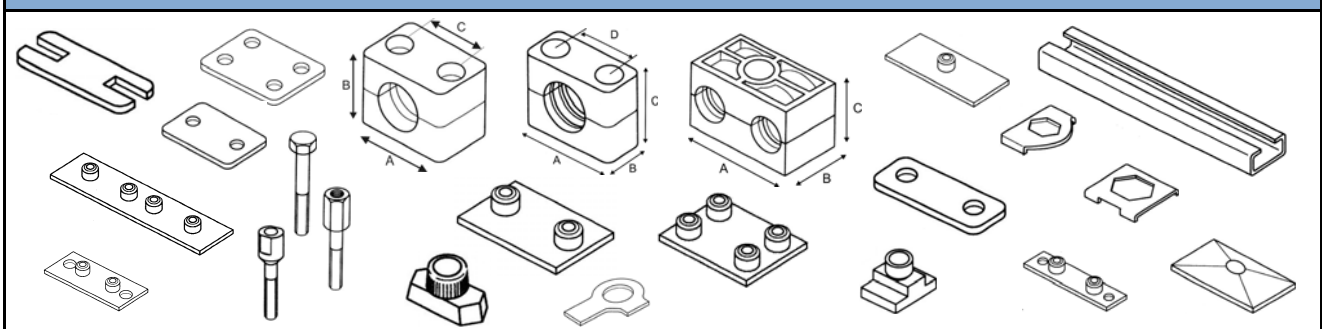



## STANDARD SERIES ORDERING EXAMPLES

**WP-XXXX-PP-CP-HB**

Support with weld plate mount, cover plate and hex bolts

WP-	XXXX-	PP-	CP-	HB
Weld Plate (WP)	Select proper tube, pipe or metric size	PP Polypropylene PA Polyamide ALU Aluminum RU Rubber	Cover Plate (CP)	Hex Bolt (HB)

**HN-XXXX-PP-CP-HB**

Support with rail nut mount, cover plate and hex bolts

HN-	XXXX-	PP-	CP-	HB
Rail Nut (HN)	Select proper tube, pipe or metric size	PP Polypropylene PA Polyamide ALU Aluminum RU Rubber	Cover Plate (CP)	Hex Bolt (HB)

**EWP-XXXX-PP-CP-HB**

Support with extended weld plate mount, cover plate and hex bolts

EWP-	XXXX-	PP-	CP-	HB
Extended Weld Plate (WP)	Select proper tube, pipe or metric size	PP Polypropylene PA Polyamide ALU Aluminum RU Rubber	Cover Plate (CP)	Hex Bolt (HB)

**XXXX-PP-LP-SB**

Stacking support with stack bolts and lock plates

XXXX-	PP-	LP	SB
Select proper tube, pipe or metric size	PP Polypropylene PA Polyamide ALU Aluminum RU Rubber	Lock Plate (LP)	Stacking Bolt (SB)

### Ordering example for stacked supports:

For a 1/2" tube standard support with weld plate mount stacked 2 high, order the following:

1 x WP-2127-PP-CP-HB

1 x 2127-PP-LP-SB



## STANDARD SUPPORT BODY PART NUMBER

### BY SIZE

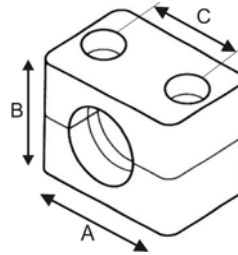

Group	O.D. Tube	Part Number	Nominal Pipe	Part Number	O.D. Metric	Part Number	Dimensions		
							A	B	C
0	1/4"	0064	1/8" (0.405" OD)	0102	6 mm	006	1.11"	1.06"	---
	3/8"	0095			8 mm	008			
					10 mm	010			
1	1/4"	1064	1/8" (0.405" OD)	1102	6 mm	106	1.34"	1.06"	.79"
	3/8"	1095			8 mm	108			
					10 mm	110			
2	1/2" 5/8"	2127 2160	1/4" (0.540" OD) 3/8" (0.675" OD)	2137 2171	12 mm	212	1.58"	1.30"	1.02"
					14 mm	214			
					15 mm	215			
					16 mm	216			
					18 mm	218			
3	3/4" 7/8" 1"	3190 3222 3254	1/2" (0.840" OD)	3213	20 mm	320	1.89"	1.38"	1.30"
					22 mm	322			
					25 mm	325			
4			3/4" (1.050" OD)	4266	28 mm	428	2.25"	1.66"	1.58"
					30 mm	430			
5	1-1/4" 1-1/2"	5318 5381	1" (1.315" OD) 1-1/4" (1.660" OD)	5334 5421	32 mm	532	2.75"	2.28"	2.05"
					35 mm	535			
					38 mm	538			
					40 mm	540			
					42 mm	542			
6	1-3/4" 2"	6445 6508	1-1/2" (1.900" OD)	6483	50 mm	650	3.39"	2.60"	2.60"
7	2-3/4" 2-1/2" 2-3/4" 3"	7572 7635 7700 7761	2" (2.375" OD) 2-1/2" (3" OD)	7603 7761	70 mm	7700	4.76"	3.69"	3.70"
					73 mm	7730			
8	4	8102	3	8889			5.79"	4.63"	4.72"

Standard series support bodies are available in the following materials:

Polypropylene	PP	e.g. PP2127
Polyamide	PA	e.g. PA2127
Aluminum	ALU	e.g. ALU2127
Rubber	RU	e.g. RU2127

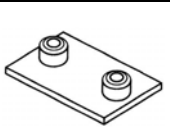
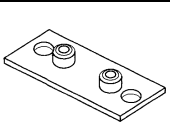
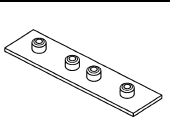
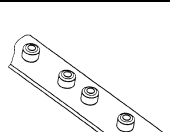
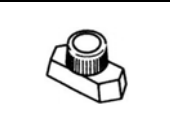
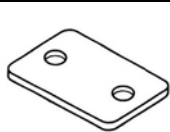
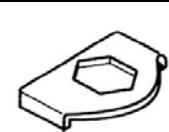
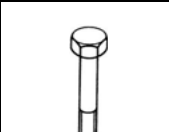
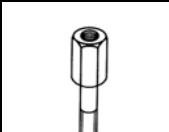

## COMPONENT PARTS FOR STANDARD SERIES SUPPORTS

									
Group	Weld Plate	Extended Weld Plate	Double Weld Plate	Group Weld Plate	Rail Nut	Cover Plate	Lock Plate	Hex Bolt	Stack Bolt
0	WP-0				HN	CP-0	LP	HB-0	SB-0
1	WP-1	EWP-1	DWP-1	GWP-1 (10 supports)		CP-1		HB-1	SB-1
2	WP-2	EWP-2	DWP-2	GWP-2 (10 supports)		CP-2		HB-2 & 3	SB-2
3	WP-3	EWP-3	DWP-3	GWP-3 (10 supports)		CP-3		HB-2 & 3	SB-3
4	WP-4	EWP-4	DWP-4	GWP-4 (10 supports)		CP-4		HB-4	SB-4
5	WP-5	EWP-5	DWP-5	GWP-5 (10 supports)		CP-5		HB-5	SB-5
6	WP-6	EWP-6	DWP-6	GWP-6 (5 supports)		CP-6		HB-6	SB-6
7	WP-7	EWP-7	DWP-7	GWP-7 (5 supports)		CP-7		HB-7	SB-7
8	WP-8	EWP-8	DWP-8	GWP-8 (5 supports)		CP-8		HB-8	SB-8

**Materials:** - Standard material for metal parts is zinc plated steel - except for weld plates and rail which are oiled finish suitable for welding  
 - 304 Stainless and 316 Stainless hardware is available

**Threads:** - All threaded hardware for standard supports has 1/4 - 20 UNC threads  
 - M6 metric threaded hardware is also available



## TWIN SERIES SUPPORTS ORDERING EXAMPLES

**TWP-XXXX/XXX-PP-TCP-HB**

Support with weld plate mount, cover plate and hex bolts

TWP-	XXXX/XXX-	PP-	TCP-	HB
Weld Plate (TWP)	Select proper tube, pipe or metric size	PP Polypropylene PA Polyamide ALU Aluminum	Twin Cover Plate (TCP)	Hex Bolt (HB)

**THN-XXXX/XXX-PP-TCP-HB**

Support with rail nut mount, cover plate and hex bolts

THN-	XXXX/XXX-	PP-	TCP-	HB
Rail Nut (THN)	Select proper tube, pipe or metric size	PP Polypropylene PA Polyamide ALU Aluminum	Twin Cover Plate (CP)	Hex Bolt (HB)

**XXXX/XXX-PP-TLW-TSB**

Stacking support with stack bolt and lock washer

XXXX/XXX	PP-	TLW-	TSB
Select proper tube, pipe or metric size	PP Polypropylene PA Polyamide ALU Aluminum	Twin Lock Washer (TLW)	Twin Stacking Bolt (SB)

### Ordering example for stacked supports:

For 1/2" tube twin support with weld plate mount stacked 2 high order the following:  
 1 x TWP-2127/127-PP-TCP-HB  
 1 x 2127/127-PP-TLW-TSB



## TWIN SUPPORT BODY PART NUMBER BY SIZE

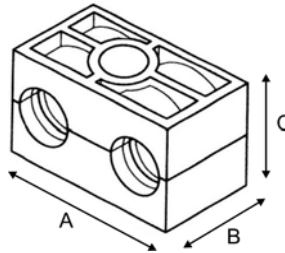







Group	O.D. Tube A1 - A2	Part Number	Nominal Pipe A1 - A2	Part Number	O.D. Metric A1 - A2	Part Number	Dimensions		
							A	B	C
1	1/4" - 1/4" 3/8" - 3/8"	1064/064 1095/095	1/8" - 1/8" (0.405" OD)	1102/102	6mm - 6mm	106/06	1.42"	1.18"	1.06"
					8mm - 8mm	108/08			
					10mm - 10mm	110/10			
					12mm - 12mm				
2	1/2" - 1/2" 5/8" - 5/8"	2127/127 2160/160	1/4" - 1/4" (0.405" OD)  3/8" - 3/8" (0.675" OD)	2137/137  2171/171	14mm - 14mm	214/14	2.09"	1.18"	1.06"
					15mm - 15mm	215/15			
					16mm - 16mm	216/16			
3	3/4" - 3/4" 7/8" - 7/8" 1" - 1"	3190/190 3222/222 3254/254	1/2" - 1/2" (0.840" OD)	3213/213	20mm - 20mm	320/20	2.64"	1.18"	1.46"
					22mm - 22mm	322/22			
					25mm - 25mm	325/25			
4			3/4" - 3/4" (1.050" OD)	4266/266	28mm - 28mm	428/28	3.23"	1.18"	1.65"
					30mm - 30mm	430/30			
5	1-1/4" - 1-1/4" 1-1/2" - 1-1/2"	5318/318 5381/381	1" - 1" (1.315" OD)	5334/334	32mm - 32mm	532/32	4.17"	1.18"	2.13"
			1-1/4" - 1-1/4" (1.660" OD)	5421/421	35mm - 35mm	535/35			
					38mm - 38mm	538/38			
					40mm - 40mm	540/40			
					42mm - 42mm	542/42			

Twin Series support bodies are available in the following materials:

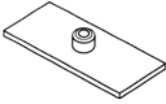
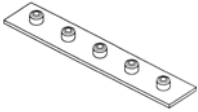
Polypropylene	PP	e.g. PP2127
Polyamide	PA	e.g. PA2127
Aluminum	ALU	e.g. ALU2127

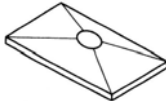

## COMPONENT PARTS FOR TWIN SERIES SUPPORTS

							
Group	Weld Plate	Group Weld Plate	Rail Nut	Cover Plate	Lock Plate	Hex Bolt	Stack Bolt
1	TWP-1	TGWP-1 (5 supports)	THN	TCP-1	TLW	THB-1	SB-1
2	TWP-2	TGWP-2 (5 supports)		TCP-2		THB-2	SB-2
3	TWP-3	TGWP-3 (5 supports)		TCP-3		THB-2	SB-3
4	TWP-4	TGWP-4 (5 supports)		TCP-4		THB-4	SB-4
5	TWP-5	TGWP-5 (5 supports)		TCP-5		THB-5	SB-5

### Materials:

- Standard material for metal parts is zinc plated steel - except for weld plates and rail which are oiled finish suitable for welding
- 304 Stainless and 316 Stainless hardware is available

### Threads:

- Twin group 1 hardware is stocked with 1/4 - 20 UNC threads. M6 metric hardware available
- Twin groups 2 - 5 hardware is stocked with 5/16 - 18 UNC threads. M8 metric hardware is available



# Heavy Duty Series Tube and Pipe Supports

## HEAVY DUTY SUPPORTS ORDERING EXAMPLES

**HWP-XXXX-HPP-HHB**

Support with heavy weld plate mount, cover plate and hex bolts

HWP-	XXXX-	HPP-	HHB
Heavy Weld Plate (HWP)	Select proper tube, pipe or metric size	HPP Polypropylene HPA Polyamide HALU Aluminum HRU Rubber	Heavy Hex Bolt (HHB)

**DHWP-XXXX-HPP-HHB**

Support with double heavy weld plate mount, cover plate and hex bolts

DHWP-	XXXX-	HPP-	HHB
Double Heavy Weld Plate (DHWP)	Select proper tube, pipe or metric size	HPP Polypropylene HPA Polyamide HALU Aluminum HRU Rubber	Heavy Hex Bolt (HHB)

**MN-XXXX-HPP-HHB**

Support with heavy rail nut, cover plate and hex bolts

MN-	XXXX-	HPP-	HHB
Milled Nut (MN)	Select proper tube, pipe or metric size	HPP Polypropylene HPA Polyamide HALU Aluminum HRU Rubber	Heavy Hex Bolt (HHB)

**XXXX-HPP-HLP-HSB**

Stacking support with stack bolts and lock plate

XXXX-	HPP-	HLP-	HSB
Select proper tube, pipe or metric size	HPP Polypropylene HPA Polyamide HALU Aluminum HRU Rubber	Heavy Lock Plate (HLP)	Heavy Stack Bolt (HSB)

### Ordering example for stacked supports:

For 1/2" tube heavy duty support with weld plate mount stacked 2 high, order the following:

1 x HWP-3127-HPP-HHB

1 x 3127-HPP-HLP-HSB



## HEAVY DUTY SUPPORT BODY PART NUMBER BY SIZE

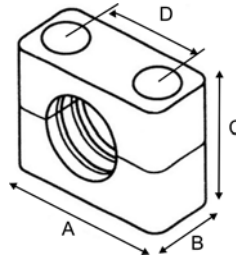







Group	O.D. Tube	Part Number	Nominal Pipe (O.D.)	Part Number	O.D. Metric	Part Number	Dimensions			
							A	B	C	D
3-H	1/4"	3064-H	1/8" (.405") 1/4" (.540") 3/8" (.675")	3103-H 3137-H 3171-H	6 mm	3006-H	2.17"	1.26"	.94"	2.87"
	3/8"	3095-H			8 mm	3008-H				
	1/2"	3127-H			10 mm	3010-H				
	5/8"	3160-H			12 mm	3012-H				
					14 mm	3014-H				
					15 mm	3015-H				
		16 mm	3016-H							
		18 mm	3018-H							
4-H	3/4"	4190-H	1/2" (.840") 3/4" (1.050")	4213-H 4267-H	20 mm	4020-H	2.76"	1.89"	1.26"	3.35"
	7/8"	4222-H			22 mm	4022-H				
	1"	4254-H			25 mm	4025-H				
					28 mm	4028-H				
					30 mm	4030-H				
5-H	1-1/4"	5318-H	1" (1.315") 1-1/4" (1.660")	5334-H 5442-H	30 mm	5030-H	3.31"	2.36"	1.49"	3.94"
	1-1/2"	5381-H			35 mm	5035-H				
					40 mm	5040-H				
					42 mm	5042-H				
					38 mm	6038-H				
6-H	1-3/4"	6445-H	1-1/4" (1.660") 1-1/2" (1.900") 2" (2.375")	6422-H 6483-H 6603-H	40 mm	6040-H	4.53"	3.54"	2.16"	5.90"
	2"	6509-H			42 mm	6042-H				
	2-1/4"	6572-H			50 mm	6050-H				
	2-1/2"	6635-H			65 mm	6065-H				
	2-3/4"	6700-H			70 mm	6070-H				
					75 mm	7075-H				
7-H	2-3/4"	7700-H	2-1/2" (2.875") 3" (3.500")	7730-H 7889-H	80 mm	7080-H	6.00"	4.72"	2.75"	7.87"
	3"	7762-H			90 mm	7090-H				
	3-1/2"	7889-H								
8-H	4"	8102-H	4" (4.500")	8114-H	90 mm	8090-H	8.07"	6.69"	3.94"	10.63"
	4-1/2"	8114-H			100 mm	8100-H				
	5"	8127-H								
9-H	5"	9127-H	5" (5.563") 6" (6.625")	9141-H 9168-H	150 mm	9150-H	9.84"	7.87"	4.53"	12.20"
	5-1/4"	9140-H								
	6"	9133-H								
	6"	9152-H								
10-H	8"	10203-H	6" (6.625") 8" (8.625")	10168-H 10219-H	220 mm	10220-H	12.60"	10.63"	6.30"	14.96"

Heavy Duty Series supports bodies are available in the following materials:

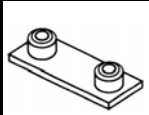
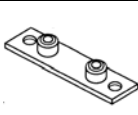
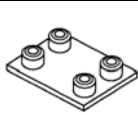
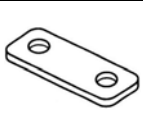
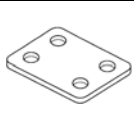
- Polypropylene    PP    e.g. PP3127-H
- Polyamide        PA    e.g. PA3127-H
- Aluminum        ALU    e.g. ALU3127-H
- Rubber         RU    e.g. RU3127-H

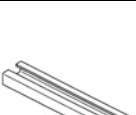
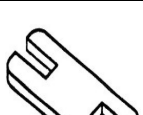

## COMPONENT PARTS FOR HEAVY DUTY SERIES SUPPORTS

											
Group	Heavy Weld Plate	Extended Heavy Weld Plate	Double Heavy Weld Plate	Heavy Cover Plate	Double Heavy Cover Plate	Heavy Hex Bolt	Heavy Stack Bolt	Heavy Rail Nut	Heavy Rail	Heavy Lock Plate	Heavy Lock Clip
3	HWP-3	EHWP-3	DHWP-3	HCP-3	DHCP-3	HHB-3	HSB-3	MN 3/8	HR100	HLP-3	HLC-3-5
4	HWP-4	EHWP-4	DHWP-4	HCP-4	DHCP-4	HHB-4	HSB-4			HLP-4	
5	HWP-5	EHWP-5	DHWP-5	HCP-5	DHCP-5	HHB-5	HSB-5			HLP-5	
6	HWP-6	EHWP-6	DHWP-6	HCP-6	DHCP-6	HHB-6	HSB-6	MN 7/16		HLP-6	HLC-6
7	HWP-7	EHWP-7	DHWP-7	HCP-7	DHCP-7	HHB-7	HSB-7	n/a	n/a	HLP-7	HLC-7
8	HWP-8	EHWP-8	DHWP-8	HCP-8	DHCP-8	HHB-8	HSB-8	n/a	n/a	HLP-8	HLC-8
9	HWP-9	EHWP-9	DHWP-9	HCP-9	DHCP-9	HHB-9	HSB-9	n/a	n/a	HLP-9	HLC-9
10	HWP-10	EHWP-10	DHWP-10	HCP-10	DHCP-10	HHB-10	HSB-10	n/a	n/a	HLP-10	HLC-10

**Materials:**

- Standard material for metal parts is zinc plated steel - except for weld plates and rail which are oiled finish suitable for welding
- 304 Stainless and 316 Stainless hardware is available

**Threads:**

- Groups 3-5 hardware is stocked with 3/8 - 16 UNC threads. M10 metric hardware available
- Group 6 hardware is stocked with 7/16 - 14UNC threads. M12 metric hardware is available
- Group 7 hardware is stocked with 5/8 - 11UNC threads. M16 metric hardware is available
- Group 8 hardware is stocked with M20 metric threads
- Group 9 hardware is stocked with M24 metric threads
- Group 10 hardware is stocked with M30 metric threads